

uSign™ 300

Signature Capture Pad

Signature Capture

The ID TECH uSign™ 300 is an electronic signature capture device with a color LCD display. Users can view their signatures in real-time during the signing process. The graphic display provides interactive text and pen-tap selection allowing customers to select and navigate transactions with the stylus. In addition, the color LCD can display company logos, promotions and custom graphics.

Speed and Efficiency

The use of electronically captured signatures is a common practice to authorize payments in Point of Service (POS) applications. Electronic signature reduces transaction time, eliminates sorting and sending paper, provides convenient electronic storage and transmission, and gives legal accountability (non-repudiation) for POS transactions. The POS applications include retail, hospitality, self-service, and quick-service restaurants.

A Convenient Package

The LCD and touch sensitive screen are housed in a rugged plastic case. The touch-sensitive LCD screen is housed in a rugged plastic case. The case provides a tethered non-electronic stylus. A metal mounting plate secures the uSign™ 300 to a desk or counter top when required. A palm rest area below the signature panel provides support to make the signing process easy.

Features and Benefits:

- Electronic signature capture with buffered signature capability
- Replaceable tethered, passive-type stylus
- Resistive touch pad
- 3.5" QVGA Color LCD
- Sampling rate up to 118 dots per second
- Touch pad resolution 1024 dots per inch
- Real time signature capture with 5:1 compression rate
- Raw data output available
- Firmware filters spikes and electronic noise
- Real-time graphics display of signature during capture
- Host control graphic and text display
- Calibration mode and functions
- Command and response driven operations through an API
- Demo application runs in Windows environments



IDTECH®
Value through Innovation

uSign™ 300 Specifications IDUB-XXXXXX

Electrical

Power Requirements: 5VDC at 170mA
120V AC adapter or USB host terminal port

Interfaces: RS-232, Baud rate from 1200 to 115200
RS-232, USB HID

Environmental

Operating Temperature: 0° C to 55° C (32° F to 131° F)
Storage Temperature: -30° C to 65° C (-22° F to 149° F)
Humidity: 10% to 95% non-condensing

Reliability

MTBF: 200,000 POH calculated (Bellcore standard)

Approvals: FCC Class B, CE, RoHS

ESD Immunity: 4KV to 8 kV min, after reset
Meets or exceeds IEC 1000-4-2

Warranty: One year, parts and labor

Mechanical

Dimensions(L) x(W) x (H): 5.75 inches (14.6 cm) x 5.1 inches (13.0 cm)x 1.57 inches (4.0 cm)

Signature Area: 3.5" QVGA Color LCD

Weight: 0.42 kg (0.93 lb)

Touchpad: Resistive

Sampling Rate: Up to 118 samples per second

Touchpad Resolution: 1024 dpi

Display Resolution: LCD Resolution: 320x240 pixels

Dual Color LED: Signature Pad or Host Controlled

Footprint:

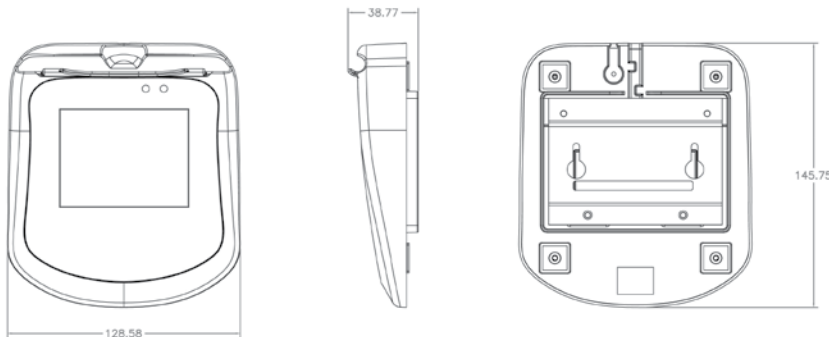

IDTECH®

Value through Innovation

Corporate Headquarters:

10721 Walker Street, Cypress, California 90630
www.idtechproducts.com
(714) 761-6368 sales@idtechproducts.com

International Sales Office

Canada & South America:

+ 450 465 5261 (Canada) robertop@idtechproducts.com

European Sales Offices:

+ 49(0) 8851 6159900 (Germany)
emea@idtechproducts.com

ISO 9001 Certified

Legacy Technology Services

We Rent & Sell All Types Of Barcode Equipment

Call now to talk to an expert

866-271-9891

www.LegacyGlobal.com

Some brands we carry



MOTOROLA

Intermec

DATALOGIC™

Honeywell

EQUINOX
PAYMENTS



About us

- Legacy Technology Services is a leading nationwide provider of mobile computing, barcode, printers and point of sale equipment and services.
- For over a decade, thousands of clients across North America have trusted us to provide equipment from leading manufacturers backed by the services to support them.

Latest Hardware from top manufacturers

- Legacy handles virtually every major manufacturer of mobile computing, barcoding and point of sale equipment.

Expert Repair and Maintenance services

- Legacy is one of the best repair facilities in North America

Discontinued product sourcing

- They don't make it anymore? Our inventory also includes manufacturer close-outs and discontinued equipment to support our clients legacy infrastructure.

Trade-in and Disposal services

- That old equipment laying around your facility may still have some value. Legacy routinely purchases equipment from our clients around the globe.
 - Data destruction
 - Hardware disposal
 - Auditing services

Dedicated client account team

- Dedicated, highly trained account managers are here to answer all your questions and provide top notch service.

Equipment rental services

- Sometimes renting is a better solution, Legacy's huge rental inventory provides the equipment you need for temporary needs and projects.



Legacy, Inc.

160 West Road,
Ellington, CT 06029

Toll Free: 866-271-9891

Fax: 888-522-4684